

Design, Fabrication, and Control of a Single Actuator Maglev Test Bed

Stephen Paschall II and Won-jong Kim

Department of Mechanical Engineering, Texas A&M University
College Station, TX 77843-3123

Abstract— This NSF Research Experience for Undergraduates project describes the design, analysis, and control of a single actuator magnetic levitation system. This system is meant as a test bed for magnetic levitation applications and experimental control systems. Utilizing a lead-lag controller, the newly constructed maglev system is made stable for the levitation of a steel ball. Despite the simplicity and low-cost of the position sensing system, it is able to detect the ball position to a resolution of 45 μm . The successful operation of this system made of relatively low-cost, low-precision components reveals that compact, cheap, integrated magnetic levitation systems are becoming more feasible for a variety of applications with the increasing availability of new materials and faster, cheaper computer processing power.

Introduction

The objective of this NSF Research Experience for Undergraduates project is to design, build, and control a magnetic levitation test bed. This test bed will be capable of levitating a small steel ball at some stable steady-state position. The levitation is accomplished by an electromagnet producing forces to support the ball's weight. A position sensor indicates the ball's vertical position and relays this to a PC based controller board. The control system uses this information to regulate the electromagnetic force on the ball.

The intent is to construct this system using relatively low-cost, low-precision components and still be able to levitate the ball with high-precision. The basic framework for the design follows from the system laid out by Trumper [1990]. In his thesis he describes his single actuator magnetic levitation system and his approach in making the system stable.

In this paper I will present the physical design aspects of this maglev system. Next I will discuss the modeling procedure of each sub-system and how these are used to create a suitable controller. Last will be the implementation of the controller into the test bed hardware to create a maglev system.

Hardware Design

The system consists essentially of a platform test bed and a PC with a DSP controller board. The test bed contains the electromagnet actuator, optical position sensor, electromagnet PWM power amplifier, and 2 DC power supplies (Figure 1).

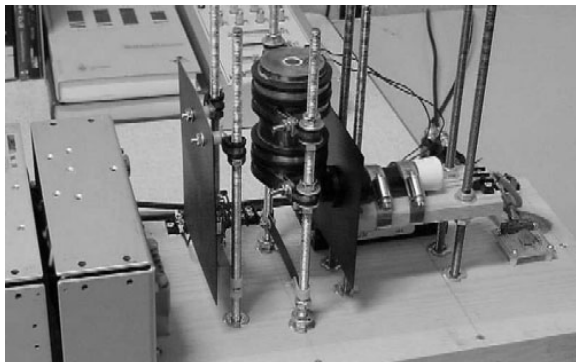

Figure 1: Magnetic Levitation Test-Bed

The system separates into two main sub-systems. The force actuation sub-system consists of an electromagnet coil with powder metal core, PWM power amplifier, and a 24 V DC power supply. The amplifier is powered by the DC power supply and based on its input control signal sends a range of current through the coil. The position sensing sub-system consists of a photocell based sensor, incandescent light source, and 15 V DC power supply. This system operates by measuring light intensity as the levitated ball shields the light source opposite of the sensor (Figure 2). To enhance the behavior of the sensor, a light shield with a vertical slit opening is placed around the photocell.

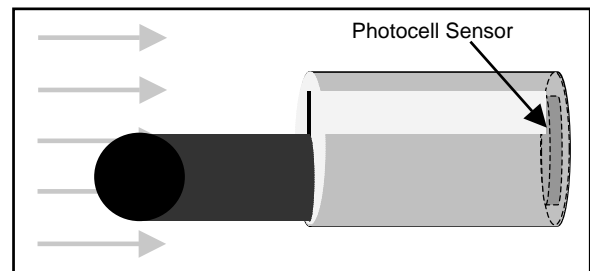

Figure 2: Positions Sensor Operation

These sub-systems are mounted together on a base plate to form the test bed. This configuration allows for portability of the system and rigid but adjustable positioning of the components. The test bed interfaces input/output sensor signals with the dSPACE DS1104 controller board within a PC. Figure 3 shows the basic system setup with physical sub-system interfaces.

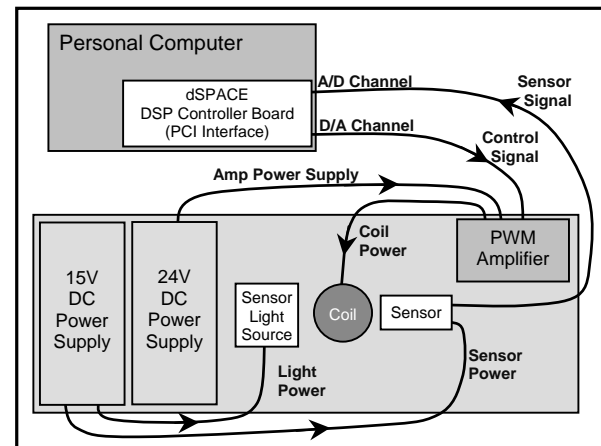

Figure 3: Magnetic Levitation System Interface Diagram

Modeling

In order to design a suitable controller for the maglev system, the sub-system components must be modeled or characterized. The sensor sub-system is modeled by measuring its voltage output as a light shield matching the ball's size moves vertically within the sensor range. Due to the small size of the photocell (~10 mm

dia.) and nature of the sensor sub-system, the sensor's outputs remains linear for approximately 3 mm. Over a larger range, sensor readings become very nonlinear. The force actuation sub-system is modeled experimentally by measuring the forces applied to the ball as a function of the coil current and vertical ball position. This force is measured using an S-beam load cell. Within the small range of travel allowed by the sensor, magnetic force as a function of current is approximately linear. The plant model for the maglev system is just the ball mass under the influence of external forces.

Dynamics and Control

Figure 4 shows the basic control system setup of the magnetic levitation system. Its magnetic field creates an upward attractive force on any magnetic object placed below. A position sensor detects the vertical position of the object and passes this information to the controller. The controller then adjusts the current to the electromagnet actuator based on the object position to create a stable levitation.

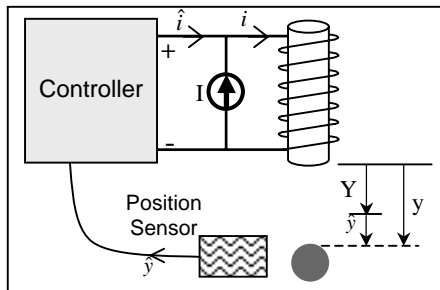

Figure 4: Magnetic Levitation System Schematic [Woodson 1968]

Using the force, plant, and sensor models discussed previously, a closed loop control system can be designed (Figure 5). A lead-lag controller is chosen to stabilize the system. Using root-locus and frequency domain analysis, the controller is designed such that the settling time is ≤ 1.0 s and percent overshoot $\leq 50\%$. This linearized controller is able to hold the steel ball in stable levitation (Figure 6).

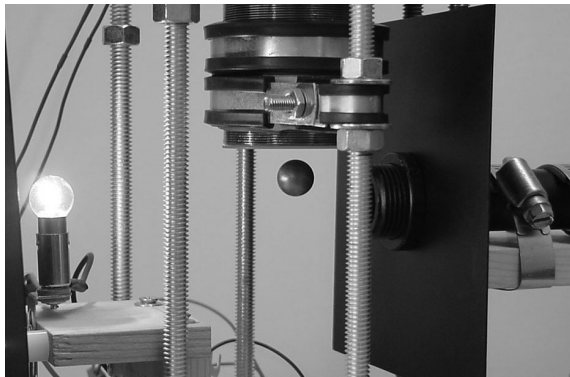

Figure 6: Stable Levitation of Steel Ball

Acknowledgments

This material is based upon work supported by the National Science Foundation under Grant No. CMS-0116642.

Conclusion

The main objective of this project was to construct a magnetic levitation test bed using relatively low-cost, low-precision components and demonstrate high-precision, stable levitation of a steel ball. This test bed can now be used as a platform for future control theory and maglev work. The project began with designing and building a portable and versatile maglev system test bed. The design was to be easily adjustable for future changes to the configuration and capable of housing new and different systems. With the maglev test bed constructed, the sub-system components were characterized to allow theoretical analysis of the entire system and design of the closed-loop controller. The control system was then implemented into the maglev test bed using a dSPACE 1104 Controller board. This enabled the steel ball to levitate at a stable steady-state position.

The successful completion of this project demonstrates the feasibility of magnetic levitation for any number of diverse applications. In addition to supporting loads (levitation), magnetic actuators can dampen vibration, apply precision force, and move objects precise distances all with no contact between surfaces and essentially no friction. This type of actuation can be used in harsh environments (corrosive, vacuum, etc.) where traditional mechanical or hydraulic actuators might not survive. A magnetic actuator can also operate in ultra clean environments without the hazard of producing contaminants from its use. The continued trend of smaller and cheaper semiconductor devices integrated with low-cost and low-complexity maglev systems can make magnetic actuation a sensible and cost effective solution to many engineering problems. Maglev systems are currently in use for applications such as bearings, high-speed trains, and manufacturing. With a streamlining of the high-precision maglev system, many unanticipated applications will develop for the future.

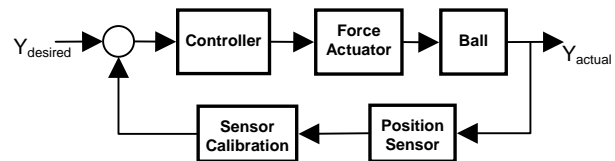

Figure 5: Magnetic Levitation System Block Diagram

References

- R. C. Dorf and R. H. Bishop, *Modern Control Systems*, 9th Edition, Prentice Hall, 2001.
- G. F. Franklin, J. D. Powell, and A. Emami-Naeini, *Feedback Control of Dynamic Systems*, 3rd Edition, Addison-Wesley Publishing Co., 1994.
- W.-J. Kim, *High-Precision Planar Magnetic Levitation*, PhD thesis, Massachusetts Institute of Technology, June 1997.
- D. L. Trumper, *Magnetic Suspension Techniques for Precision Motion Control*, PhD thesis, Massachusetts Institute of Technology, September 1990.
- H. H. Woodson and J. R. Melcher. *Electromechanical Dynamics*, John Wiley & Sons, Inc., 1968.