

The Feedback Control System of electromagnetic Suspension Using Kalman Filter

Jeong-Min Jo and Young-Jae Han, and Chang-Young Lee, Bu-Byung Kang

Korea Railroad Research Institute, New Transportation Systems Research Center, Super Speed Train Research Team, P.O. Box 360-1, Woram-Dong, Uiwang-Si, Gyeonggi-Do, South Korea, 437-757

jmjo@krri.re.kr, yjhan@krri.re.kr, cylee@krri.re.kr, bbkang@krri.re.kr

ABSTRACT: The basic element of the EMS suspension is the electromagnet system, which suspends the vehicle without contact by attracting forces to the rails at the guideway. The suspension of a vehicle by attractive magnetic forces is inherently unstable and consequently it is continuously adjusted by the strength of the suspending electromagnet from rail irregularity and bending of the guideway. In order to improve reliable tracking, it needs to get feedback signals without measurement delay time. In this paper the concept of feedback control system with Kalman Filter in EMS is proposed. The input signals in the feedback control system are an air-gap and an acceleration signal. The air-gap signal with noise from the gap sensor is transformed to the filtered air-gap signal y without measurement delay time by using Kalman Filter. The filtered air-gap signal is transformed to a relative velocity and a relative acceleration signal. Then it multiplies these values by gain matrix in order to get the actuator's reference voltage value. The simulation results show that the dynamic responses of the suspension system can be improved by reducing the influence of measurement delay time of air-gap signals.

1 INTRODUCTION

Magnetic levitation (maglev) is an innovative transportation technology that via replacement of mechanical components by electronics overcomes the technical restrictions of wheel on rail technology. Compared with traditional railways maglev systems have high speed, high safety, less pollution, low energy consumption and high capacity[1].

The basic element of the EMS suspension is the electromagnet system, which suspends the vehicle without contact by attracting forces to the rails at the guideway. The suspension of a vehicle by attractive magnetic forces is unstable and consequently it is continuously adjusted by the strength of the suspending electromagnet from rail irregularity and bending of the guideway. In order to improve reliable tracking, it needs to get control signals without measurement delay time. In this paper a method to estimate the air gap using Kalman filter is proposed and overcome such problem. The simulations are carried out to show that the air-gap controller with the little measurement delay time provides higher system stability and fast step response.

2 MAGNETIC SUSPENSION MODEL

2.1 Linearized Magnetic Suspension Model

The magnetic suspension model is simplified by linearization following Meisenholder and Nagurka. Terms of second and higher order are neglected.

The total magnetic force is

$$F \approx \frac{M_1}{2} N_c I_c - \frac{M_1}{h_0} N_c I_c (h - h_0) + M_1 N_i i \quad (1)$$

Where $h = h_0$, $i = i_0 = 0$ And the dynamic magnetic force is expressed as

$$f = -\frac{M_1}{h_0} N_c I_c (h - h_0) + M_1 N_i i \quad (2)$$

The voltage law is also linearized at the nominal air gap, where $h = h_0$, $i = i_0 = 0$, $\dot{h} = \dot{h}_0 = 0$ and $\dot{i} = \dot{i}_0 = 0$. Then

$$\dot{i} \approx M_2 u - M_3 i + M_4 \dot{h} \quad (3)$$

Eq (3) is the voltage model which is used in this study. The state-space representation of the above equation[3] is

$$\begin{bmatrix} \dot{h} \\ \ddot{h} \\ \dot{i} \end{bmatrix} = \begin{bmatrix} 0 & 1 & 0 \\ \frac{K_z}{m} & 0 & -\frac{K_i}{m} \\ 0 & \frac{K_z}{K_i} & -\frac{R_0}{L_0} \end{bmatrix} \begin{bmatrix} h \\ \dot{h} \\ i \end{bmatrix} + \begin{bmatrix} 0 \\ 0 \\ \frac{1}{L_0} \end{bmatrix} u \quad (4)$$

$$\text{Where } K_i = \frac{\mu_0 N^2 A i_0}{2h_0^2}, \quad K_z = \frac{\mu_0 N^2 A_0^2}{2h_0^2}, \quad K_i = \frac{\mu_0 N^2 A}{2h_0^2}$$

2.3 The Conventional Levitation Controller Structure

LPF (Low Pass Filter) has been used to reduce the signal noise of the measurement gap signals in conventional levitation controllers.

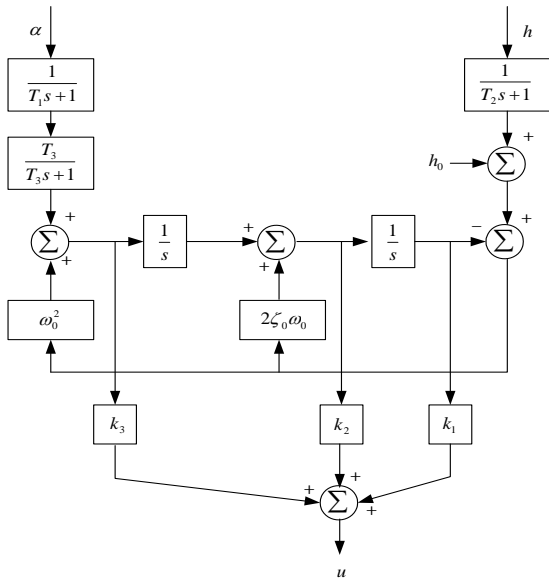

Figure 1. The conventional controller for EMS

The input signals in controller of figure 1 are a gap and an acceleration signal. These signals are transformed to filtered gap and filtered acceleration signal. The filtered gap signal is as following.

$$h_f = \frac{2\omega^2}{s^2 + 2\xi_0\omega_0 + 2\omega_0^2} \left(\frac{h}{T_2 s + 1} - h_0 \right) + \frac{\alpha}{s^2 + 2\xi_0\omega_0 s + 2\omega_0^2} \quad (5)$$

1.4 The Gap Estimation using Kalman-Filter

The original plant model is of the following form

$$\begin{aligned} \dot{x}(t) &= A(t)x(t) + B(t)u(t) + H(t)\omega(t) \\ y &= C(t)x(t) + v(t) \end{aligned} \quad (6)$$

where

$x(t)$ is a vector of the system states, $u(t)$ is a vector of the system inputs, $y(t)$ is a vector of the system outputs, $w(t)$ is a vector of Gaussian white noise with strength $Q_n(t)$, $v(t)$ is a vector of Gaussian white noise with strength $R_n(t)$, $w(t)$ and $v(t)$ are uncorrelated.

$A(t), B(t), C(t), D(t), H(t)$ are time-dependent matrices with appropriate dimensions.

This is a linear time-variant control system. For the system outputs, the air gap at a position, the bogie acceleration and velocity and the magnet current are assumed to be measured.

From equation (6) the discrete model of a plant is defined as

$$\begin{aligned} x_{k+1} &= \Phi_k x_k + \Gamma_k u_k + w_k \\ y_k &= H_k x_k + v_k \end{aligned} \quad (7)$$

Where

$$\Phi = \begin{bmatrix} 1 + \Delta t^2 \frac{1}{2} \frac{K_z}{m} & & & \\ \frac{K_z}{m} (\Delta t + \Delta t^3 \frac{1}{6} \frac{K_z}{m}) - \Delta t^3 \frac{1}{6} \frac{K_z^2}{m^2} & 1 + \Delta t^2 \frac{1}{2} \frac{K_z}{m} - \frac{K_i}{m} (\Delta t^2 \frac{1}{2} \frac{K_z}{K_i} - \Delta t^3 \frac{1}{6} \frac{R_0}{L_0} \frac{K_z}{K_i}) & & \\ \Delta t^2 \frac{1}{2} \frac{K_z}{K_i} \frac{1}{m} - \Delta t^3 \frac{1}{6} \frac{R_0}{L_0} \frac{K_z^2}{K_i m} & \Delta t \frac{K_z}{K_i} - \frac{R_0}{L_0} (\Delta t^2 \frac{1}{2} \frac{K_z}{K_i} - \Delta t^3 \frac{1}{6} \frac{R_0}{L_0} \frac{K_z}{K_i}) & & \\ & -\Delta t^2 \frac{1}{2} \frac{K_i}{m} + \Delta t^3 \frac{1}{6} \frac{K_i}{m} \frac{R_0}{L_0} & & \\ & -\Delta t^3 \frac{1}{6} \frac{K_z K_i}{m^2} - \frac{K_i}{m} (\Delta t - \Delta t^2 \frac{1}{2} \frac{R_0}{L_0} + \Delta t^3 \frac{1}{6} (-\frac{K_z}{m} + \frac{R_0^2}{L_0^2})) & & \\ 1 + \frac{K_z}{K_i} (-\Delta t^2 \frac{1}{2} \frac{K_i}{m} + \Delta t^3 \frac{1}{6} \frac{K_i}{m} \frac{R_0}{L_0}) - \frac{R_0}{L_0} (\Delta t - \Delta t^2 \frac{1}{2} \frac{R_0}{L_0} + \Delta t^3 \frac{1}{6} (-\frac{K_z}{m} + \frac{R_0^2}{L_0^2})) & & & \end{bmatrix}$$

$$\Gamma = \begin{bmatrix} -\Delta t^3 \frac{1}{6} \frac{K_i}{m} \frac{1}{L_0} \\ (-\Delta t^3 \frac{1}{2} \frac{K_i}{m} + \Delta t^3 \frac{1}{6} \frac{K_i}{m} \frac{R_0}{L_0}) \frac{1}{L_0} \\ (\Delta t - \Delta t^2 \frac{1}{2} \frac{R_0}{L_0} + \Delta t^3 \frac{1}{6} (-\frac{K_z}{m} + \frac{R_0^2}{L_0^2})) \frac{1}{L_0} \end{bmatrix}$$

3 SIMULATION RESULTS AND CONSIDERATION

Levitation controller using gap signals with measurement delay time don't get an expected performance. In this paper, a new air gap estimator to improve the performance of levitation controller is proposed. The estimated gap signal which has little measurement delay time is used as a feedback value in the levitation controller.

Simulations are performed to confirm the improvement of performance in levitation controller with the little measurement delay time.

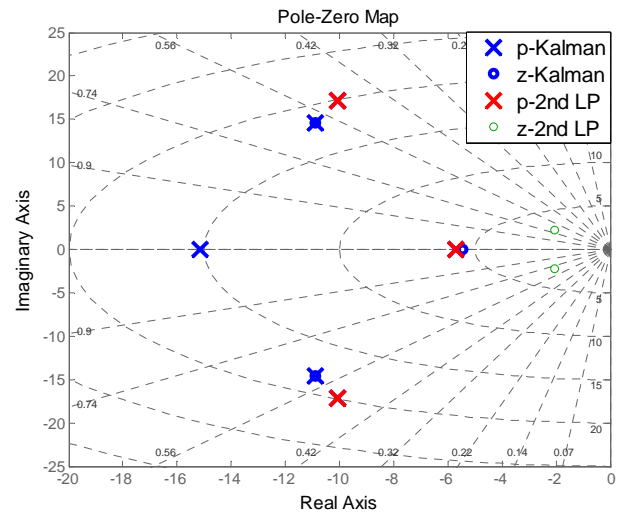

Figure 2. Pole Zero Map for the Feedback Control System

Figure 2 shows pole zero map for the feedback control system in case of using 2nd LPF and Kalman Filter. From the figure 3, the response time of the feedback control using kalman filter is reduced by the little measurement delay time as compared to that of the feedback control using 2nd LPF in step response because the pole of the feedback control system using Kalman filter is far from imaginary

axis than that of control system using 2nd LPF. Figure 3 ~Figure 4 shows step responses under the initial condition in the feedback control system using 2nd LPF and Kalman estimator respectively. From the simulation results the filtered gap signal h_{LPF} includes much noise than the estimated gap signal $h_{estimated}$ using Kalman filter. And Simulation results in the starting point show that initial value is zero in the estimated gap signal $h_{estimated}$

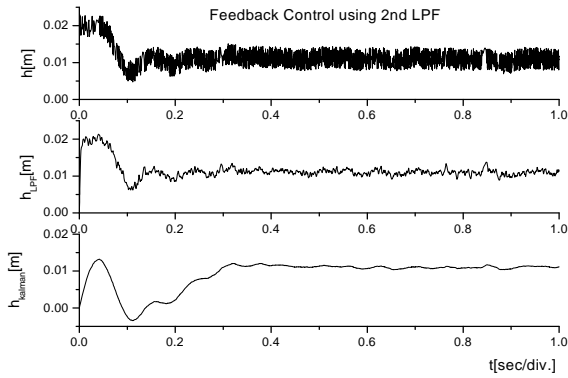

Figure 3. Step Responses under the initial condition (Feedback Control Using 2nd LPF)

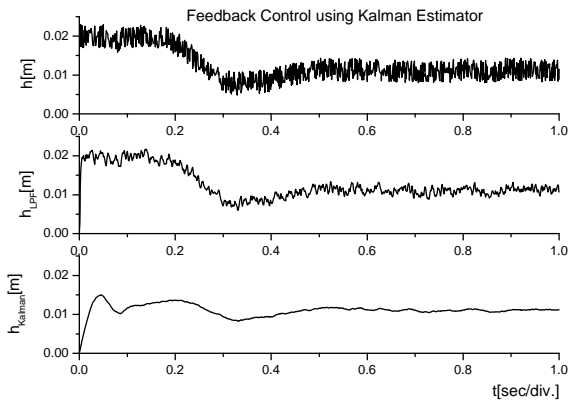

Figure 4. Step responses under the initial condition

Figure 5~Figure 6 shows step responses in the feedback control system using 2nd LPF and Kalman estimator respectively.

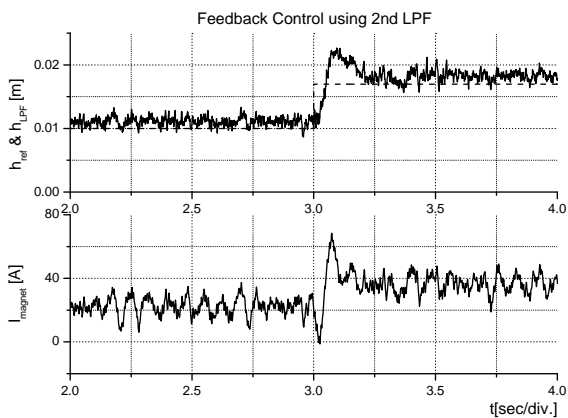

Figure 5. Step Responses of the feedback control using 2nd LPF

From the simulation results, the response time of the feedback control system using Kalman estimator is faster than that of the feedback control system using the filtered gap signal h_{LPF} because the estimated gap signal which has little measurement delay time is used as a feedback value in the levitation controller.

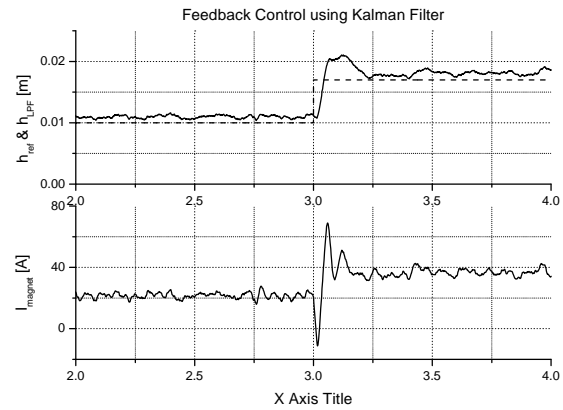

Figure 6. Step responses of the feedback Control using Kalman Filter

4 CONCLUSIONS

In this paper the design of the levitation controller using Kalman estimator is considered in order to improve the performance of the electromagnetic suspension system. We cannot obtain an expected performance from a conventional levitation controller using gap signals with measurement delay time. The feedback control system using Kalman estimator is proposed to improve the performance of levitation controller. The air-gap signal estimated by Kalman filter has little measurement delay time. Simulation results show that the dynamic responses of the suspension system can be improved by reducing the influence of measurement delay time of air-gap signals

This work was supported by Royalty Project through Korea Institute of Construction & Transportation Technology Evaluation and Planning (KICTEP) funded by Korean Ministry of Land, Transport and Maritime Affairs (10ENGF-C055954-01-000000)

5 REFERENCES

- [1] Mohammad Ali Sadrnia, and Atiyeh haji jafari, "Robust Control Design for maglev Train with Parametric Uncertainties Using μ -synthesis," International Journal of Mathematical, Physical and Engineering Sciences, vol 1, No 2
- [2] Huiguang Dai, dynamic Behavior of maglev Vehicle/Guideway System with Control, submitted in partial fulfillment of the requirements for the degree of Doctor of Philosophy, 2005
- [3] P.K. Sinha, "electromagnetic Suspension Dynamics & Control," IEE Control Engineering Series, 1987